

# **GPSMAP 2006/2010**

## **GPS 17**

*Installation Guide*

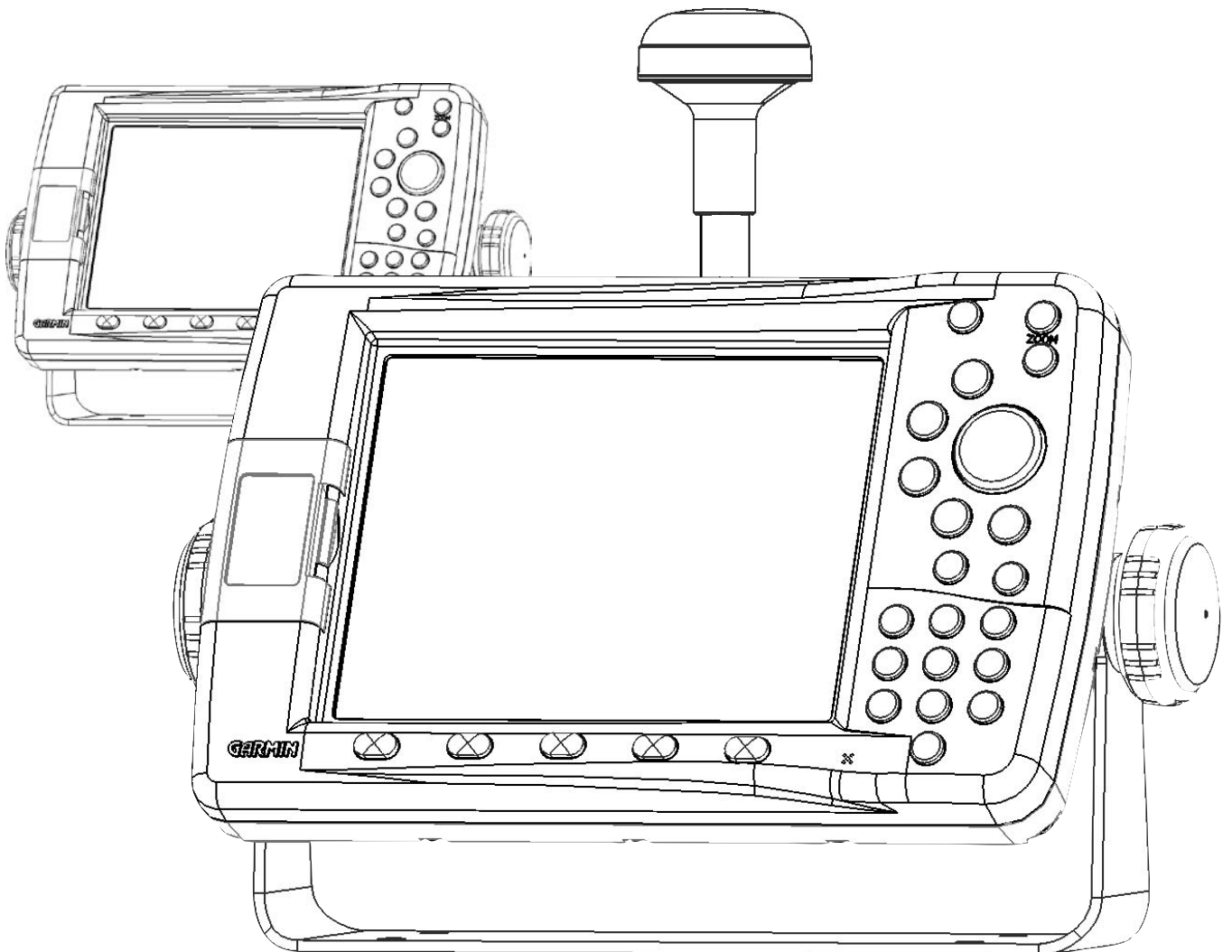

# GPSMAP 2006 / 2010/ GPS 17 Installation Guide

## Introduction

The GPSMAP 2006/2010 must be properly installed according to the following instructions to get the best possible performance. To complete the installation, you'll need the appropriate fasteners, tools, and mounts listed in each section. These items should be available at most marine dealers. **When in doubt, seek professional assistance.**

## Surface Mount

### Tools

Drill	Pencil
Drill Bit	Screw Driver

- **Mounting Hardware (Fasteners) Not Included**

### Installing the Bail Mount and Unit:

1. Using the Bail Mount as a template, mark the location of the four mounting holes with the pencil. Be sure to leave at least two inches of clearance behind the unit for the wiring connector.
2. Using an appropriate size drill bit, drill pilot holes for the fasteners that you choose to use.
3. Secure the Bail Mount to the surface with the fasteners.
4. Loosen the Mounting Knobs.
5. Slide the unit into the Bail Mount and tighten the Mounting Knobs.

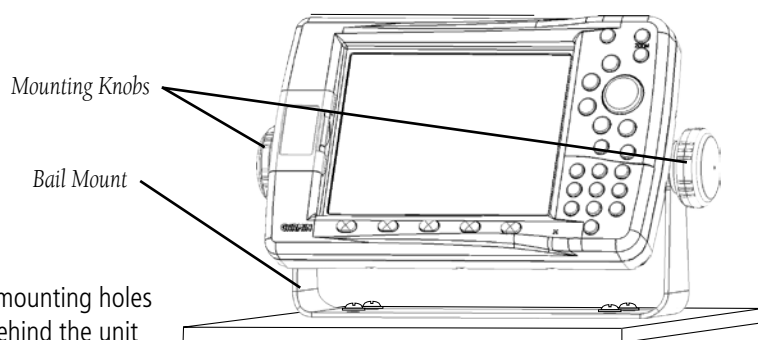

**Bail Mount**

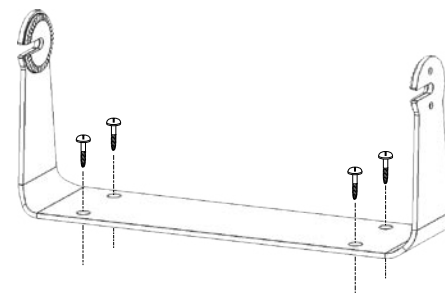

## Flush Mount

### Tools

Jig Saw	Center Punch
Scissors	Masking Tape
Drill Bits	1/16" (2mm) Allen (Hex) Wrench
Drill	Hammer
Sockets or Pliers	

### Included Mounting Hardware

4 - 3mm Studs

4 - Flat Washers

8 - 3mm Hex Nuts

(continued on next page)

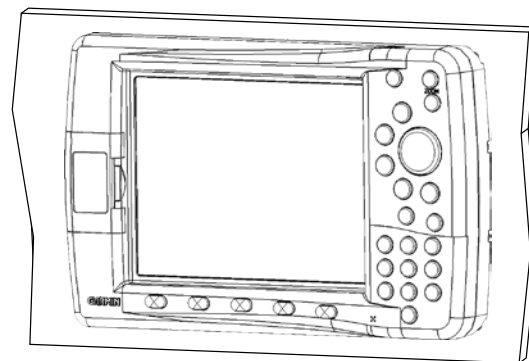

**Flush Mount**

# GPSMAP 2006 / 2010 / GPS 17 Installation Guide

## Flush Mounting the GPSMAP 2006/2010:

1. Trim the Flush Mount Template and tape in the desired location.
2. Using the Center Punch, indent the center of each Mounting Hole location.
3. Using an 1/8" (3mm) drill bit, drill the four Mounting Holes.
4. Using a 3/8" (6mm) drill bit, drill a hole for a location to begin cutting the mounting surface.
5. Using the Jig Saw, cut the mounting surface along the inside of the dashed line indicated on the template. **Be very careful when cutting this hole, there is only a small amount of clearance between the unit and the Mounting Holes.**
6. Install the four Mounting Studs into unit by screwing the shorter, threaded section in to the back of the unit. Use a 1/16" (2mm) Allen Wrench to tighten the Mounting Studs until the stop contacts the case. Be careful not to overtighten as this may damage the Mounting Stud! The studs have a reusable thread-locking patch pre-applied from the factory.
7. Place the unit in position in the cut out in the mounting surface.
8. Place washers over the Mounting Studs, then thread on one Hex Nut per Mounting Stud. Tighten all four until the unit is snug against the mounting surface. Install and tighten the second Hex Nut on all four Mounting Studs to lock the first one in place.

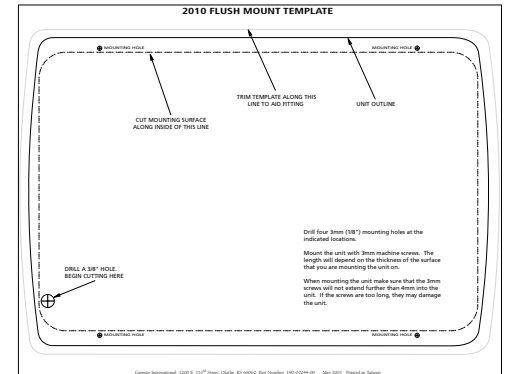

Flush Mount Template

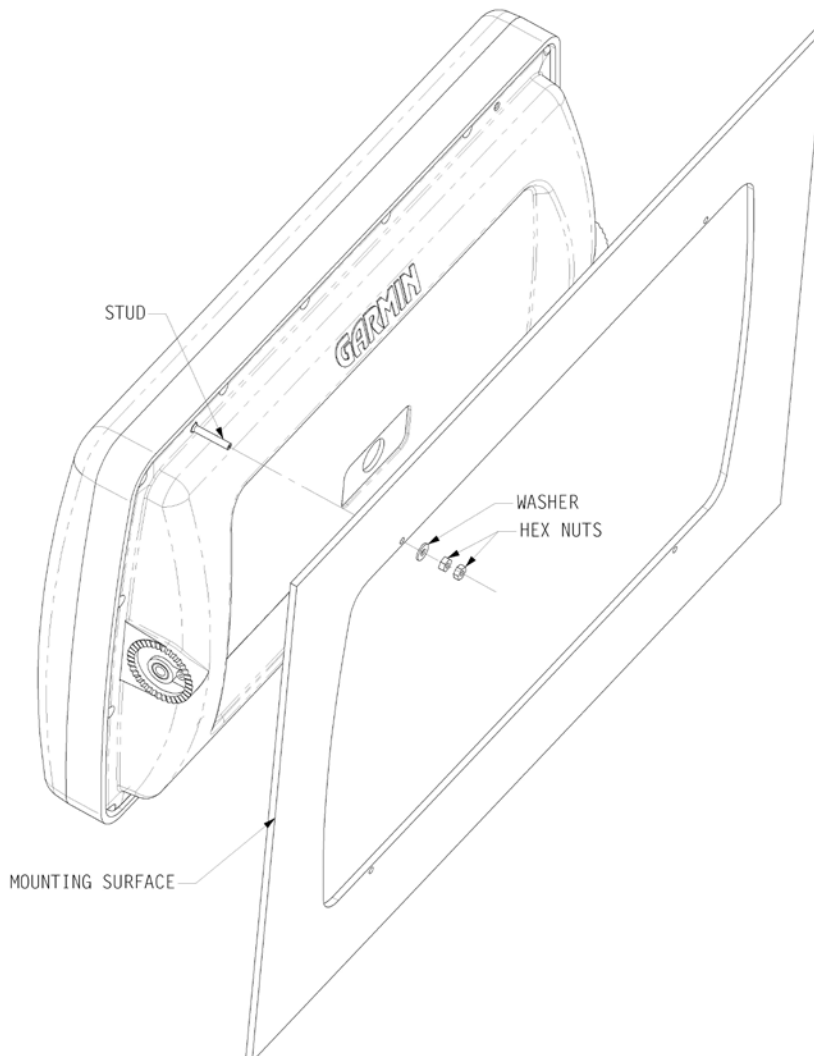

# GPSMAP 2006 / 2010 / GPS 17 Installation Guide

## Installing the GPS 17

The GPS 17 installs on any standard 1" OD Marine Mount. The cable can be run externally or if possible, through the center of the mount. The GPS 17 connects to the 18-pin Power/Data Cable on the GPSMAP 2006/2010 and provides the GPS signal for the unit.

The antenna should be mounted in a location that has a clear, unobstructed view of the sky in all directions to ensure the best reception. Avoid mounting the antenna where it will be shaded by the boat's superstructure, a radome antenna, or mast. Sailboat users should avoid mounting the antenna high on the mast to prevent inaccurate speed readings caused by excessive heeling. The unit will provide more stable readings if it is located nearer to water level. Most marine VHF and LORAN antennas should not seriously degrade the GPS antenna's reception. **It is recommended that the antenna be mounted at least 3 ft. away from (preferably above) the path of any radar beam.** If interference is experienced, relocate the antennas further apart. Never paint the GPS antenna or clean it with harsh solvents.

### Mounting the GPS 17 with cable outside mount:

1. Place the cable in the vertical slot along the side of the base of the unit.
2. Screw the GPS 17 onto the mount. Make sure that you do not overtighten the head. It is possible to tighten the unit to the point that the cable may be cut in two.
3. With the GPS 17 and mount installed, fill the remaining gap in the cable exit on the with a marine sealant.
4. When running the cable, attempt to keep the cable away from sources of electronic interference.

### Mounting the GPS 17 with cable through mount:

1. Position the mount in the desired location and mark the approximate center of the mount
2. Drill a hole large enough for the cable to pass through at the marked location.
3. Slide the cable through the mount and screw the GPS 17 onto the mount.
4. Fasten the mount to the boat
5. When running the cable, attempt to keep the cable away from sources of electronic interference.

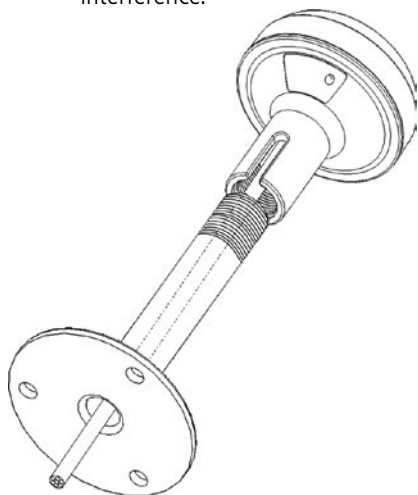

GPS 17 with cable run internally

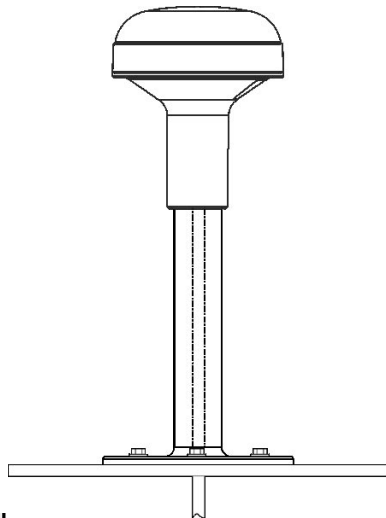

Three common sources of interference for GPS signals are:

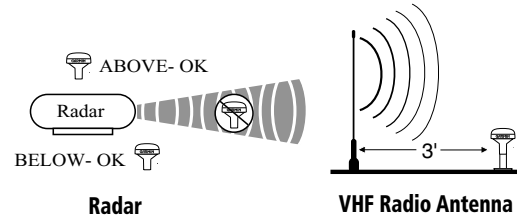

Radar

VHF Radio Antenna

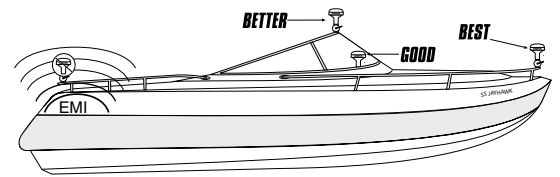

EMI (Electromagnetic Interference) from engine components

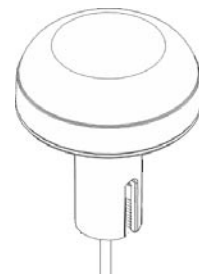

GPS 17

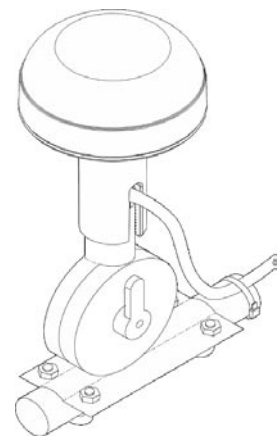

GPS 17 with cable run externally

# GPSMAP 2006 / 2010 / GPS 17 Installation Guide

## Wiring

There are two wiring diagrams provided for you convenience. The first is a simple hook-up showing the GPSMAP 2006/2010 (using the 18-pin wiring harness), the GPS 17 and the alarm circuit. The Alarm does not have to be wired for the unit to function. The second is a complete wiring diagram showing the GPSMAP 2006/2010 (using the 18-pin wiring harness) interfacing with a variety of different equipment. The extra 5-pin wiring harness that came with the unit is intended for future interfacing features and does not require connection. Refer to the wiring diagram that will best suite your needs. Make sure that all connections are good. For extra lengths of wire, 24 AWG (unless otherwise noted on wiring diagram), shielded, twisted-pair wiring is recommended. We advise soldering all connections and sealing the connection with heat shrink tubing. If you experience difficulty wiring the unit, please contact an installation professional in your area.

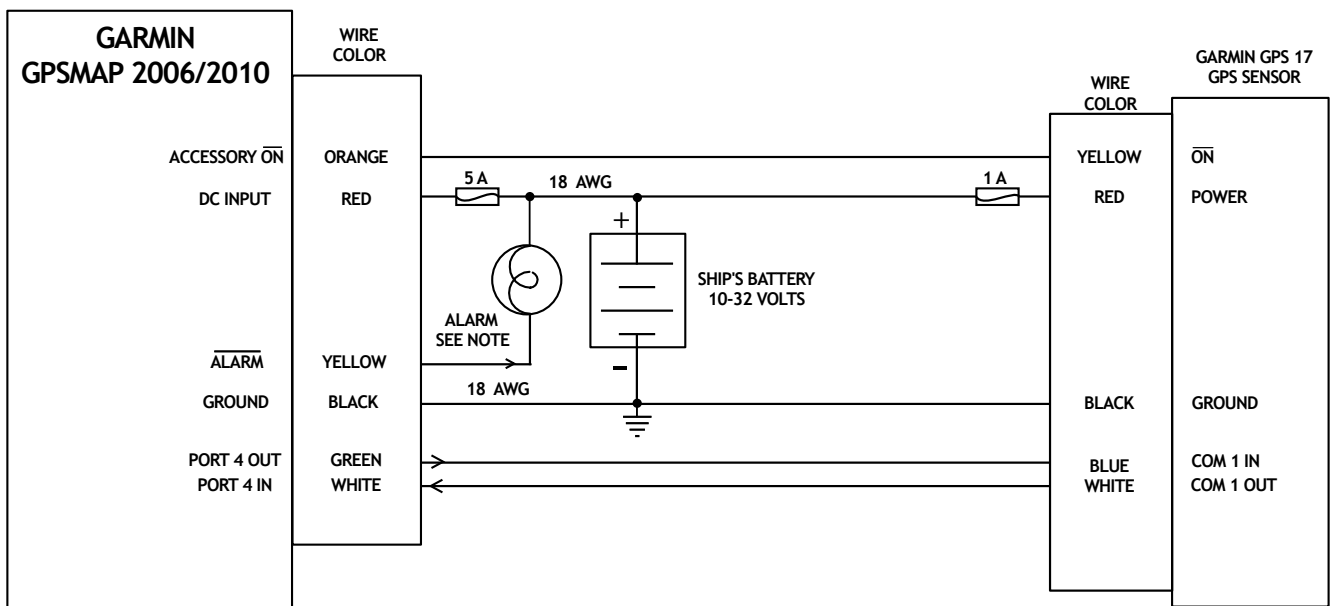

NOTE:  
THE ALARM OUTPUT CAN BE USED TO DRIVE A LAMP, HORN, OR BOTH.  
MAXIMUM CURRENT IS 100 MILLIAMPS. A SWITCH OR RELAY CAN BE USED  
TO SELECT BETWEEN VISUAL AND AUDIBLE ALERTS, IF REQUIRED

Diagram 1 - Basic Hook-up

# GPSMAP 2006 / 2010 / GPS 17 Installation Guide

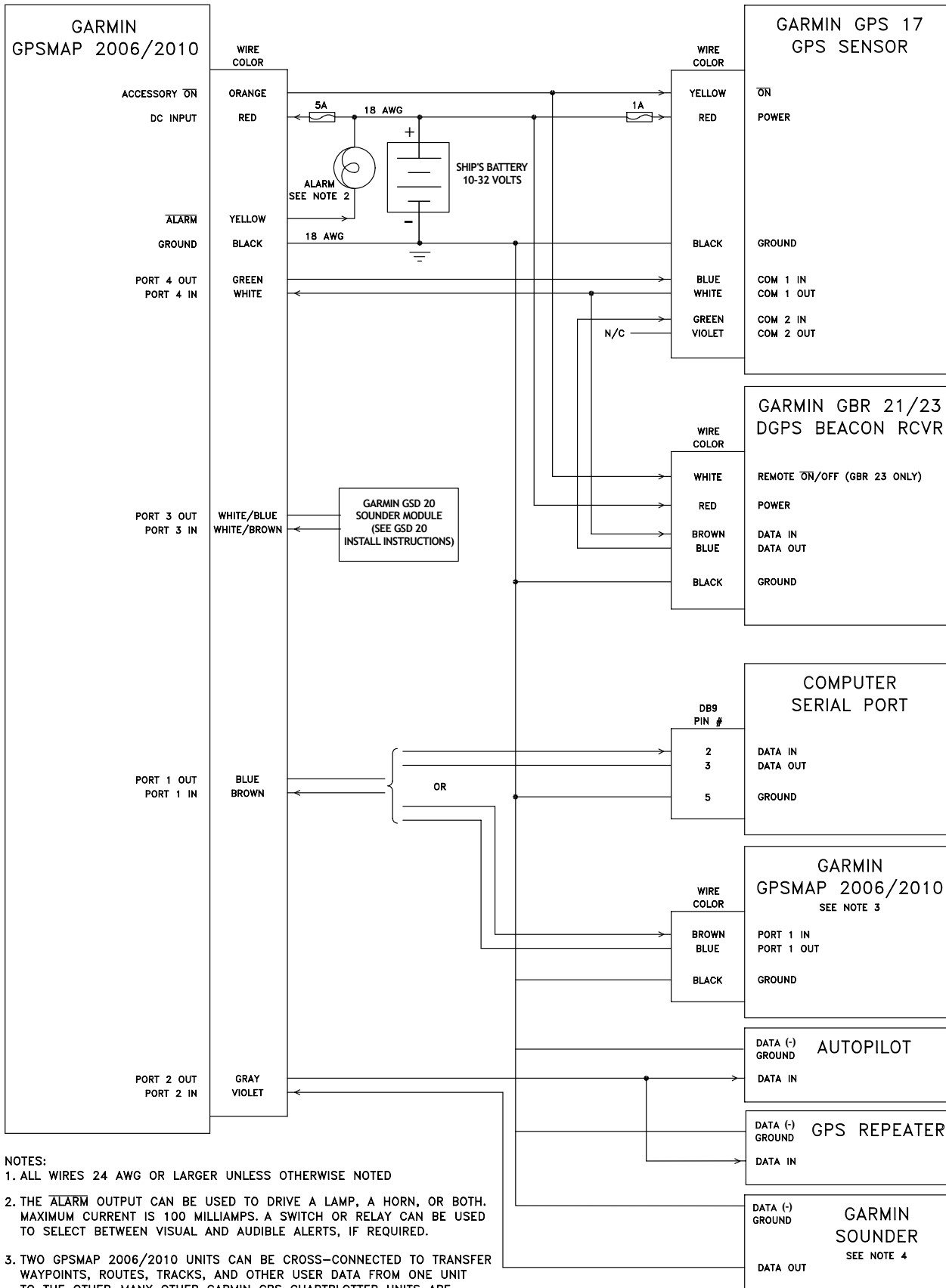

- NOTES:
1. ALL WIRES 24 AWG OR LARGER UNLESS OTHERWISE NOTED
  2. THE ALARM OUTPUT CAN BE USED TO DRIVE A LAMP, A HORN, OR BOTH. MAXIMUM CURRENT IS 100 MILLIAMPS. A SWITCH OR RELAY CAN BE USED TO SELECT BETWEEN VISUAL AND AUDIBLE ALERTS, IF REQUIRED.
  3. TWO GPSMAP 2006/2010 UNITS CAN BE CROSS-CONNECTED TO TRANSFER WAYPOINTS, ROUTES, TRACKS, AND OTHER USER DATA FROM ONE UNIT TO THE OTHER. MANY OTHER GARMIN GPS CHARTPLOTTER UNITS ARE COMPATIBLE WITH THIS INTERFACE AS WELL.
  4. A GARMIN SOUNDER UNIT (OTHER THAN GSD 20) CAN PROVIDE WATER DEPTH, WATER TEMPERATURE, AND SPEED VIA NMEA DATA FOR DISPLAY ON THE GPSMAP 2006/2010.

Diagram 2 - Complete Interface

# GPSMAP 2006 / 2010 / GPS 17 Installation Guide

## **Final Wiring Connection**

Once all the wiring is complete, plug the 18-pin harness into the center connector on the backside of the GPSMAP 2006/2010. The 5-pin port on the right side is intended for future interfacing features and does not require connection at this time.

With power applied to the circuit, you may test the installation by pressing the **POWER**  key on the front of the unit. See the Owner's Manual for steps on initializing the receiver.

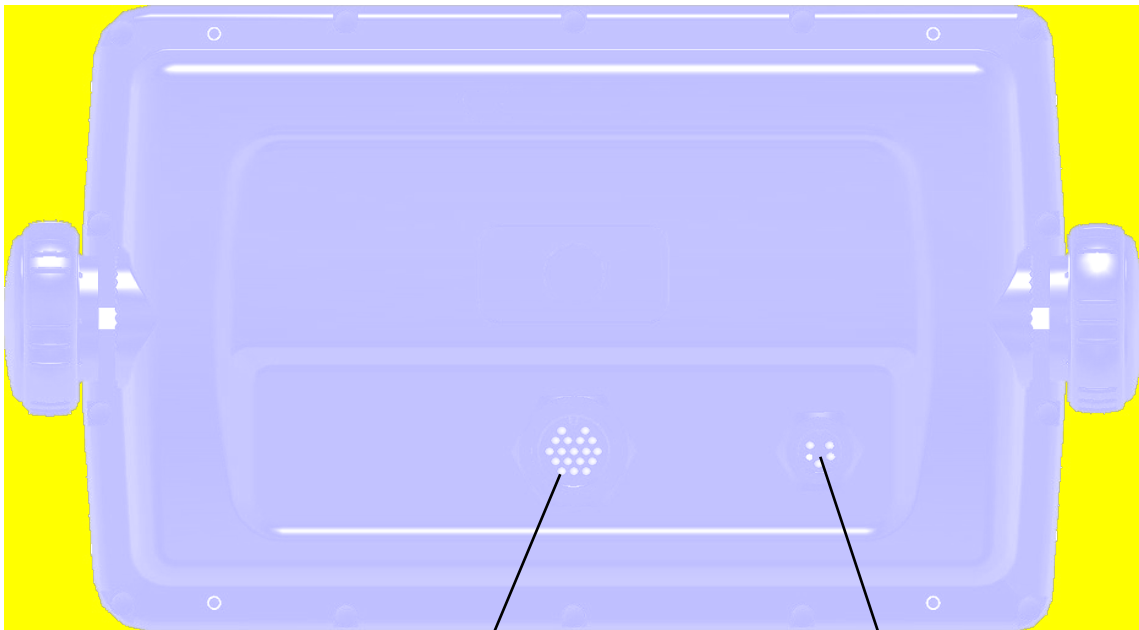

*18-Pin Connector*

*5-Pin Connector  
(for future use)*



© 2001-2004 GARMIN Ltd. or its subsidiaries

Garmin International, Inc.  
1200 East 151<sup>st</sup> Street, Olathe, Kansas 66062, U.S.A.

Garmin (Europe) Ltd.  
Unit 5, The Quadrangle, Abbey Park Industrial Estate, Romsey, SO51 9DL, U.K.

Garmin Corporation  
No. 68, Jangshu 2<sup>nd</sup> Road, Shijr, Taipei County, Taiwan

[www.garmin.com](http://www.garmin.com)

Part Number 190-00228-01 Rev. E